

ENVIRONMENTAL SOLUTIONS FOR COMMERCIAL REFRIGERATION

CDU-S - Product réf. R02A1A

Evaporating temperature	°(C)	-10	0	+5
Cooling capacity	(kW)	3.3	3.65	3.82
Electric power input	(kW)	1.6	1.69	1.71
Operation temperature (to guarantee cooling capacity)	Evaporating (Min/Max)	°(C)	-10 ~ +5	
	Ambient (Min/Max)	°(C)	-15 ~ +43	
Dimensions	Height x Width x Depth	(mm)	670 X 950 X 360	
Weight		(kg)	54	
Noise pressure level ⁽¹⁾	1 meter away	(dB(A))	46	
Compressor	Type		Inverter Hermetic Scroll	
	Motor Output	(kW)	1.8	
	Speed Min/Max	(Hz)	30 ~ 80	
Heat Exchanger	Technology Type		Microchannel HX	
Refrigerant	Type / GWP		R744 (CO ₂) / 1	
Power Supply	Phases / Voltage/Frequency ⁽²⁾	(-/V/Hz)	3 phases / 220 / 50 or 60	



(1) Conditions : T° Ambient + 32°C, Compressor Speed 80hz

(2) Coming soon : 1 phase / 230 / 50 or 60

MAIN BENEFITS

- First 100% CO₂ refrigerant solution for convenient stores and small cooling capacities
- Extremely compact
- Very silent operation

- Very low refrigerant charge, absolutely neutral impact on the environment
- Modular, flexible and easy installation

Electric Diagramm

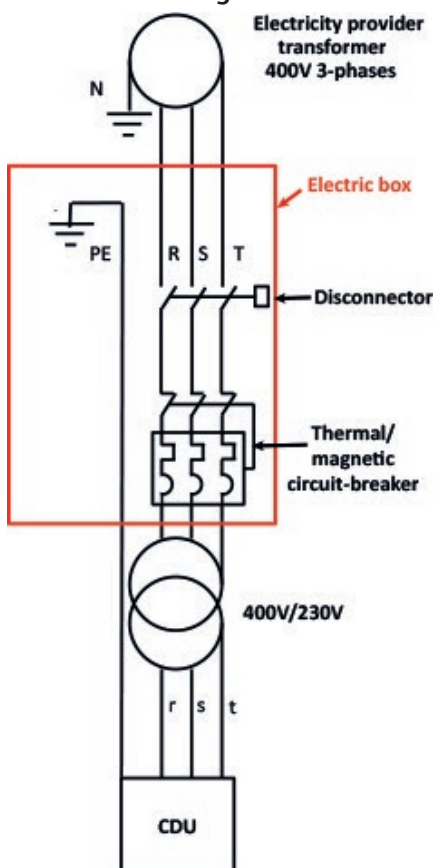

Piping Diagramm

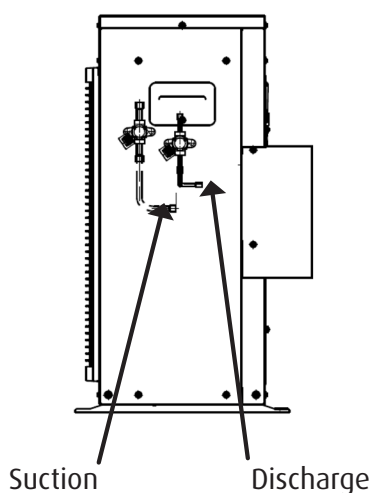

Dimensions

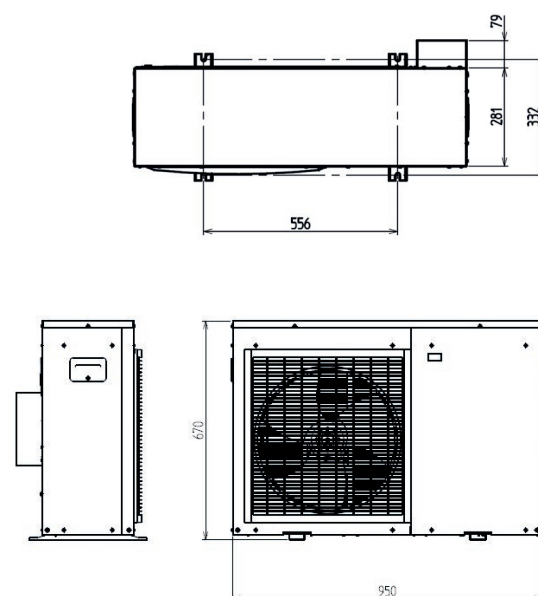

Dimensions for connecting pipe

Thickness (mm)

Diameter (mm)	High pressure side	Low pressure side
φ 6.35	0.8	0.8
φ 9.52	1.0	0.8

SANDEN CO₂ Technology made in Europe

Natural refrigerant

Non-flammable, non-toxic

CO₂ is one of the safest refrigerants. In case of accidental leak, there is no risk for the end-users or for the technician.

Reduced global warming potential

(GWP = 1)

Contrary to F-gases that are commonly used in the field of commercial refrigeration, CO₂ refrigerant has a minimal environmental impact (less green housing effect). Its global warming potential of 1 is at least 1,430 times smaller than HFCs. For instance, 1 kg of R410a = 2,100 tons of CO₂!

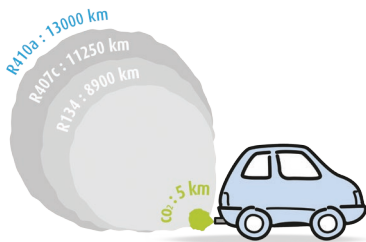

CO₂ refrigerant: At least to 1,430 times less greenhouse than commonly-used refrigerants!

SANDEN-made components

SANDEN designs and manufactures CO₂ compressors & exchangers used in its products.

Efficient systems require efficient components. We design and manufacture the CO₂ compressors, gas coolers and evaporators that are assembled in all SANDEN product ranges. That is how we ensure the best quality standards.



Design and manufacturing

For optimized performance in real-life conditions

With 54 locations in 23 countries, SANDEN is committed to providing the most optimized solutions to local markets. The launch of commercial refrigeration products range results from an intense collaboration between Japanese and European engineers.

Expertise in CO₂ technology

Strong experience in multiple applications

The SANDEN group has developed unique knowledge in CO₂ technology encompassing a large panel of applications. SANDEN manufactures CO₂ heat pump water heaters, vending machines and retail refrigeration systems worldwide.



SandenVendo G-Drink vending machine based on SANDEN CO₂ technology

